

ACOM0539 "X" Complementi - Portasalviette e portavassoio / Extras - Towel or shelf holder

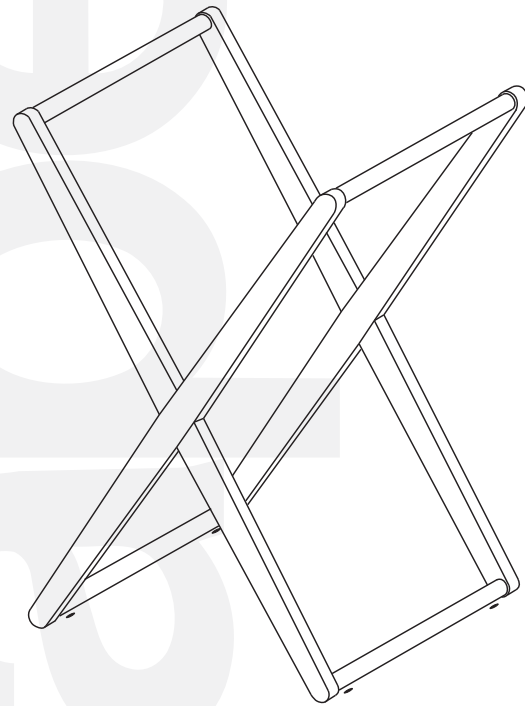

n. 2 fiancate
side parts

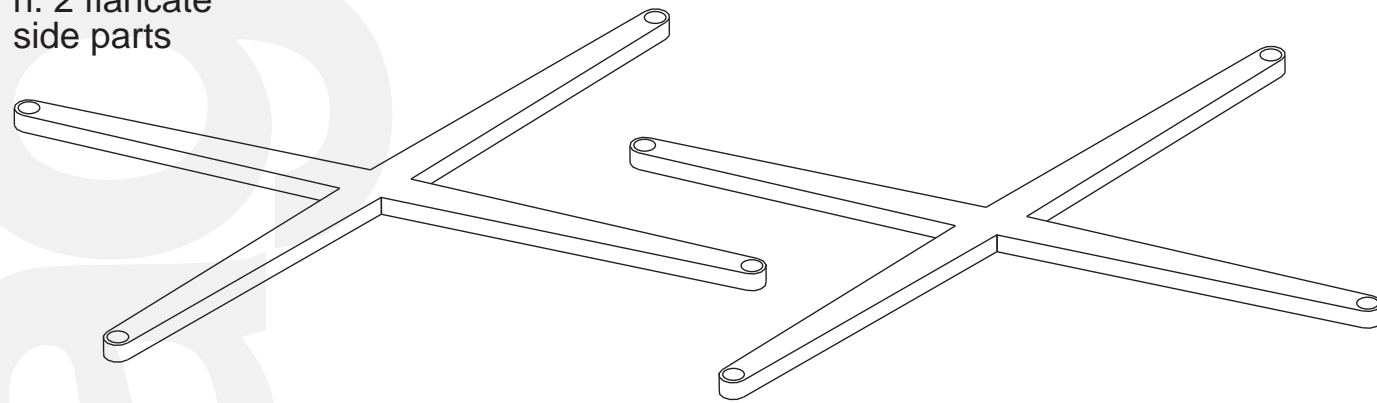

n. 2 traversi per piedini
cross braces for feet

n. traversi
cross braces

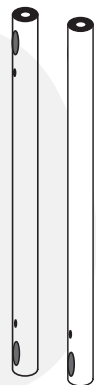

STRUMENTI / TOOLS

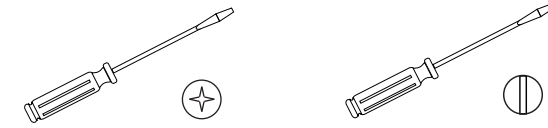

FERRAMENTA

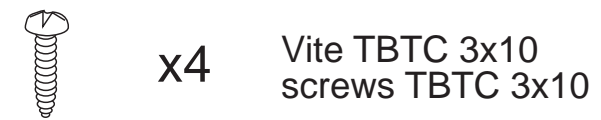
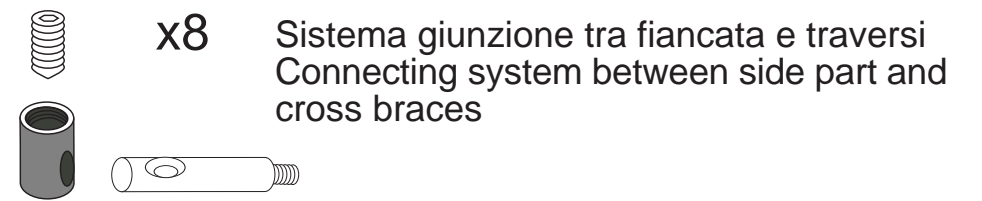

MANUTENZIONE / MAINTENANCE:

Si raccomanda di utilizzare un panno umido, preferibilmente in cotone bianco e semplice sapone di Marsiglia ed asciugare. Per ridurre la manutenzione è consigliabile asciugare le superfici dopo l'uso con panno morbido, senza l'utilizzo di detersivi. Non utilizzare prodotti a base di solventi quali alcool, trielina, diluenti, acqua ragia, ammoniaca ecc. e prodotti abrasivi.

We recommend using a damp cloth, preferably of white cotton, and simple Marseilles soap. To reduce the need for maintenance, it is advisable to dry the surfaces with a soft detergent-free cloth after use. Do not use solvent-based products (such as alcohol, trichlorethylene, diluents, ammonia, etc.) or abrasive products.

ACOM0539 "X" Complementi- Portasalviette e portavassoio / Extras - Towel or shelf holder

